



**FLEXIBLE
CARD CLOTHING**



FLEXIBLE CARD CLOTHING for woollen

Since 1879 BIOTTI Card Clothing has specialized in the production of flexible card clothing for woollen and worsted carding machines.

With the **constant modernization** and updating of our plant and production techniques, we have become leaders in the manufacturing of **high quality card clothing**, which is now sold and appreciated by customers all over the world.

Thanks to years of experience we can offer first-rate and reliable products, as well as **technical assistance** in choosing and mounting the various types of card clothing onto our client's machinery.

The choice of flexible card clothing depends on a number of factors and

to obtain optimum spinning results we always ask our customers what type of material is to be introduced into the carding machine and the resulting NM.

Once supplied with this information and a diagram or detailed description of the machine, we can then suggest the **best combination** of foundation and steelwire necessary to produce the most efficient carding.

Since the choice of card clothing depends on so many different factors, we don't rely on standardized charts but **examine every individual case**, so as to determine the best possible technical solution to fit each customer's needs.

Foundations

felt card clothing

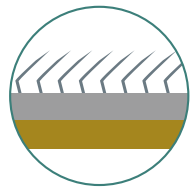

FELT 4.50 mm
7 - 9 - 11 PLY
FELT 3.00 mm
5 - 6 - 7 PLY

felt/vulc card clothing

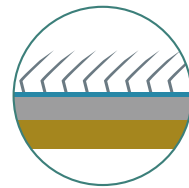

FV 4.50 mm
7 - 9 PLY

rubber felt card clothing

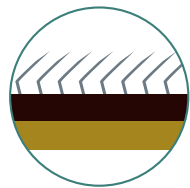

RF 4.00 mm
7 - 9 - 11 PLY

Other names for RF Card Clothing:
OPCR (Oil Proof Cushion Rubber)
CF (Cushion Felt)
BCR (Black Cushion Rubber)

vulc card clothing

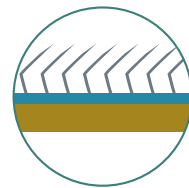

VULC rubber 1.00 mm
5 - 6 - 7 - 8 - 9 PLY

Fancy fillet

foundation soft sponge 3.00 mm 5-6 PLY

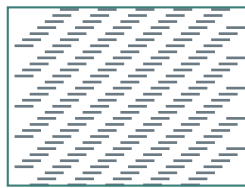

SETTING diagonal
WIDTH 38-39/46-48 mm **HEIGHT** 25 mm

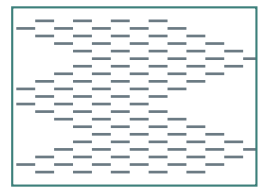
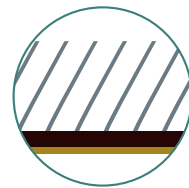

SETTING special ZZ
WIDTH 46 mm **HEIGHT** 25 mm

foundation soft sponge 3.00 mm 5-7 PLY

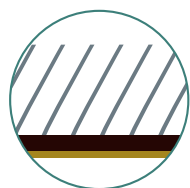

CLEARSTRIP
WIDTH 38 mm **SETTING** 3 x 3
HEIGHT 25-28.5-38 mm

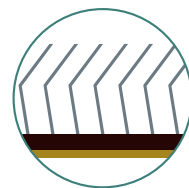

LOW BEND
WIDTH 38 mm **SETTING** 3 x 3
HEIGHT 25-28.5-31.5 mm

Mainly used steel wires

bright hardened and tempered wire
tinned-nickel wire
stainless steel wire

ENGLISH	CONTINENTAL	ROUND (MM)	○	NUMBER	BICONVEX (MM)	○
21	0	0.810		17/21	1.420 - 0.810	
22	2	0.710		18/22	1.215 - 0.710	
23	4	0.630		19/23	1.015 - 0.630	
24	6	0.580		20/24	0.910 - 0.580	
25	8	0.530		21/25	0.810 - 0.530	
26	10	0.480		22/26	0.710 - 0.480	
27	12	0.430		23/27	0.630 - 0.430	
28	14	0.405		24/28	0.580 - 0.405	
29	16	0.380		25/29	0.530 - 0.380	
30	18	0.355		26/30	0.480 - 0.355	
31	20	0.330		27/31	0.430 - 0.330	
32	22	0.305		28/32	0.405 - 0.305	
33	24	0.280		29/33	0.380 - 0.280	
34	26	0.255		30/34	0.355 - 0.255	
35	28	0.230		31/35	0.330 - 0.230	
36	30	0.205		32/36	0.305 - 0.205	

PPSI

CONTINENTAL WIRE	PPSI	UK STYLE	PPSI	BICONVEX WIRE	PPSI
6	140	10/26	240	20/24	105
8	180	12/27	300	21/25	140
10	205	14/28	320	22/26	170
12	230	16/29	340	23/27	195
14	270	18/30	420	24/28	230
16	310	20/31	460	25/29	260
18	335	22/32	500	26/30	285
20	385	24/33	580	27/31	325
22	425	26/34	660	28/32	360
24	475	28/35	800	29/33	400
26	535			30/34	450
28	600				
30	670				

Finishing

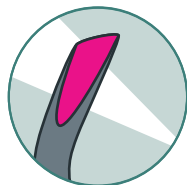

SIDE GRINDING



EXTRA HARDENED POINTS



POLISHED POINTS



Flexible card clothing standard width

	CONTINENTAL (MM)	UK AND U.S.A. STYLE (MM - ")
CYLINDER	50 - 60 - 70	57 - 51 2 ¼ - 2
DOFFER	56 - 60	57 - 51 2 ¼ - 2
WORKERS	45 - 50	38 1 ½
STRIPPER	30 - 35	25.4 1
TRANSFER	51	38 1 ½
FANCY	38 - 46	38 1 ½
DOFFER CLEANER	40	38 1 ½

Width of flexible card clothing and foundation can be determined by working width of woollen carding machine and diameters of rollers to be covered.

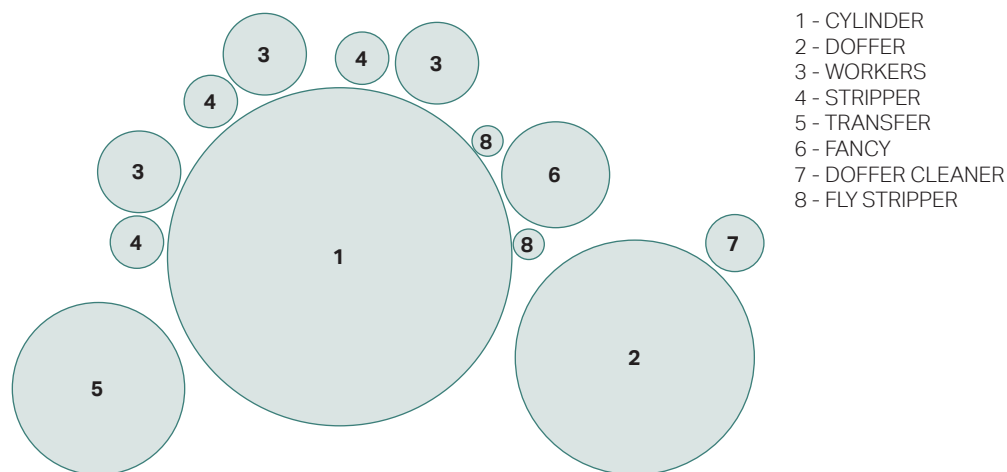

Flexible card clothing suggested tensions

FOUNDATION	PLY	KG/MM ... WIDTH
FANCY SS / RF 3.00 MM	5	2.8
FANCY SS / RF 3.00 MM	7	3.0
RF / CF / OPCR 4.00 MM	7	3.8
RF / CF / OPCR 4.00 MM	9	4.6
RF / CF / OPCR 4.00 MM	11	5.4
FELT 3.00 MM	5	3.0
FELT 3.00 MM	7	3.4
FELT 4.50 MM	7	3.6
FELT 4.50 MM	9	4.4
FELT 4.50 MM	11	5.2
VULC 1.00 MM	5	2.7
VULC 1.00 MM	6	2.9
VULC 1.00 MM	7	3.1
VULC 1.00 MM	8	3.3
VULC 1.00 MM	9	3.5

7 PLY RF 60 mm 3.8x60 = Kg

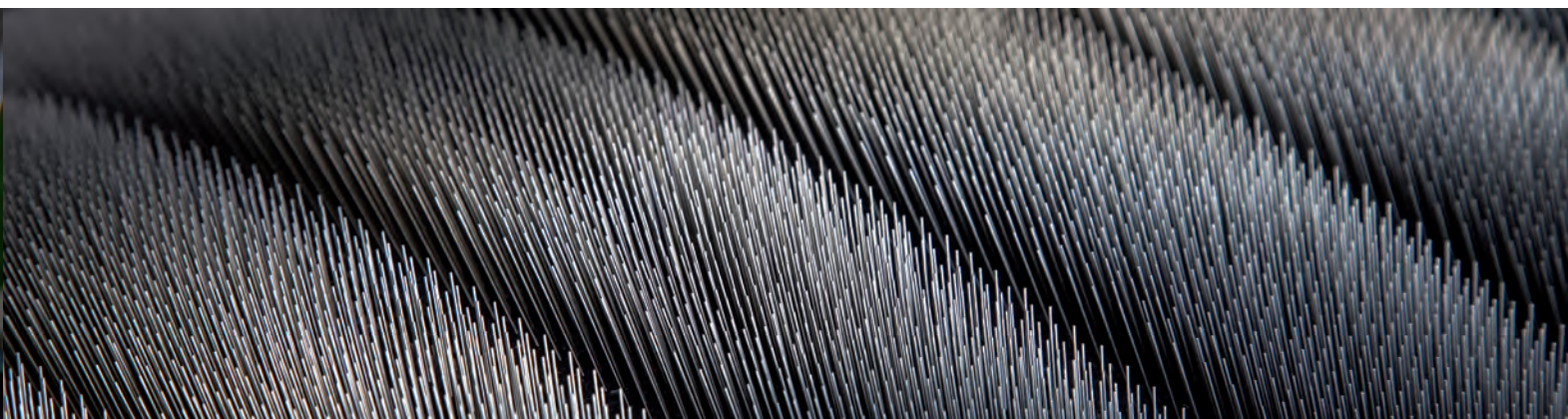
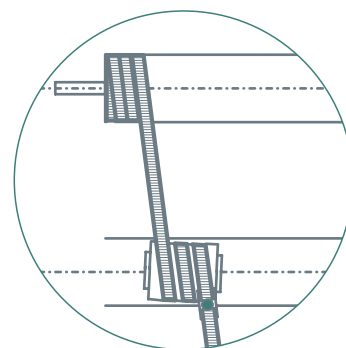

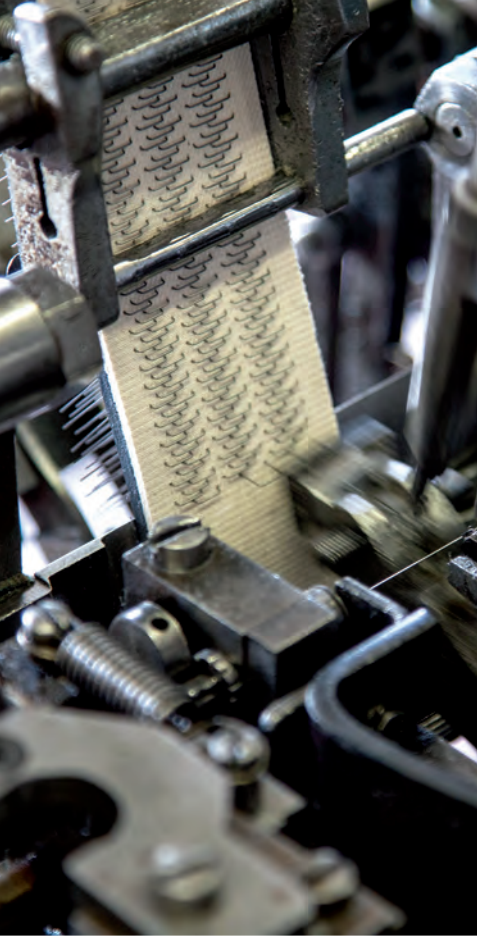

Production

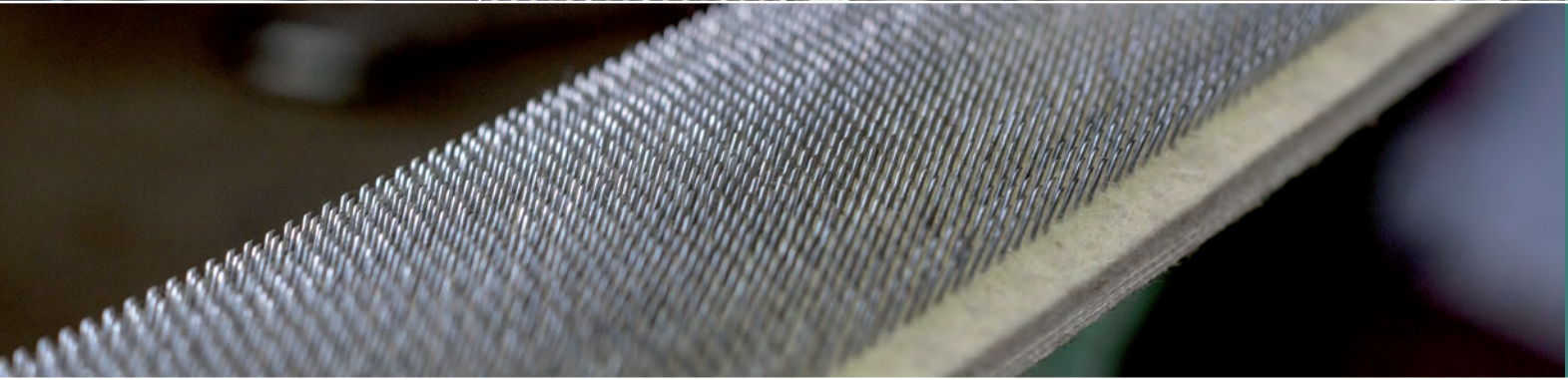

Quality control

Finishing

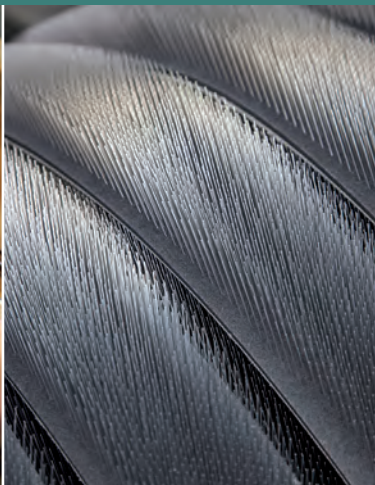

Edge cutting

Handling

Packing and shipping



BIOTTI Card Clothing was founded back in 1879 and over the years has gradually become the most up-to-date and efficient manufacturer of flexible card clothing, metallic wire and raising fillets in Italy. The Company's success is due to the **constantly high quality** of its product which is made possible by using the **finest raw materials** combined with the **efficiency** and **modernity** of its production facilities and the professionalism of its employees, as well as the rigorous control of its finished product.

Once recognized as a leader in its field in Italy, the Company decided to expand into foreign markets and its products are now sold in all continents, in over **60 countries** around the world.

Today, thanks also to effective management, **BIOTTI Card Clothing** has been able to consolidate this success which allows it to confidently look to a future of continuing growth and development.

BIOTTI card clothing s.r.l.

via s. giovanni bosco, 3
28921 verbania
italy

tel. +39 0323 53355
fax +39 0323 53357
sales@biotti.it
www.biotti.it

